

SYNTHETIC MUSIC SYSTEMS
HAND MADE ANALOGUE SYNTHESIZERS

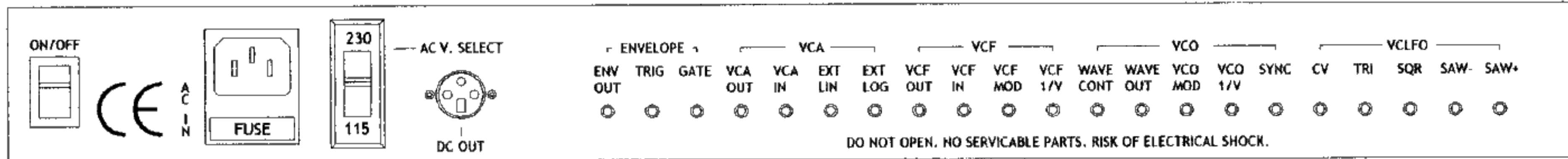

OPERATORS MANUAL

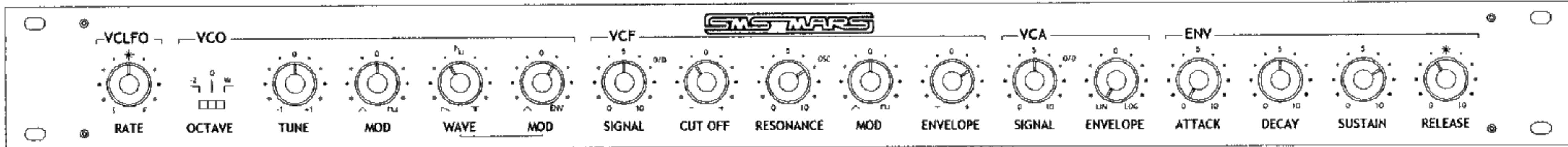

CONTENTS

INTRODUCTIONS _____	2
INTERNAL MODULATION ROUTE _____	3
INTERNAL SIGNAL ROUTE _____	3
ISOLATION PATCH _____	3
VCLFO _____	4
VCO _____	5
VCF _____	7
VCA _____	9
ENV _____	11
SPECIFICATION _____	13
SPECIFICATION _____	14
COMING SOON _____	15
BLANK PATCH CHARTS _____	-

INTRODUCTION TO SYNTHETIC MUSIC SYSTEMS

Greetings fellow noise makers. If your reading this you've probably just taken delivery of a superb piece of analogue music making equipment we call the MARS.

SMS is a small friendly company hand building analogue music synthesizers. We're driven by a passion for electronic music and the classic analogue sound.

Our objective at SMS is to keep all aspects of our business on a very personal level. We take a great deal of care and pride in every instrument we build and would like each and every one to lead a long and healthy life, so if we can help you in anyway please get in touch.

INTRODUCTION TO THE MARS

The MARS (Modular Analogue Rack Synthesizer) is a highly versatile music synthesizer. As a stand-alone unit it can create the "classic" sounds associated with analogue synthesizers: silky smooth filter sweeps, squealing lead lines and deep rumbling basses. Its open ended architecture has been carefully designed for expansion. The front controls allow the five synthesizer circuits within the MARS (VCLFO, VCO, VCF, VCA, ENV) to be isolated, the sockets on the rear panel allow signal and modulation routing to be configured to your specification allowing for true modular synthesis.

Two optional expansion units, The PLANET7 and The BOB, have been designed to interface with the MARS. The BOB (Break Out Box) will bring the rear patch sockets to the front of the rack with the addition of a three colour noise generator. The PLANET7 is designed to sit between two MARS units and will also bring the rear patch sockets to the front with the addition of a three colour noise generator, ring modulator, sample and hold, mixer, DC level shifter, lag processor, four attenuator/invertors, multi-jack and two front-to-rear bus lines.

INTERNAL MODULATION ROUTE

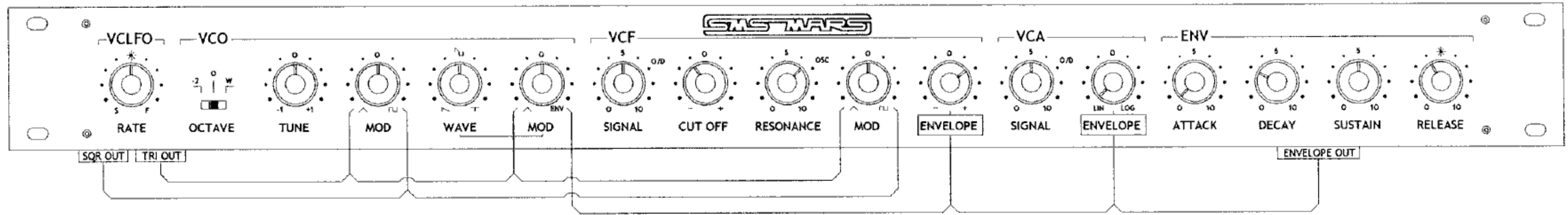

INTERNAL SIGNAL ROUTE

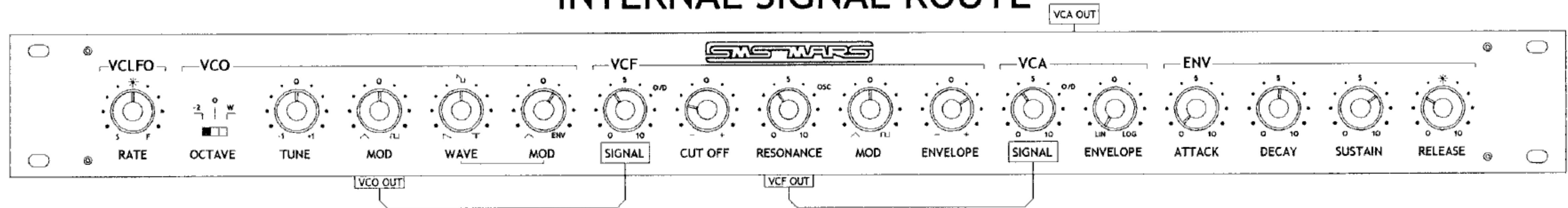

ISOLATION PATCH

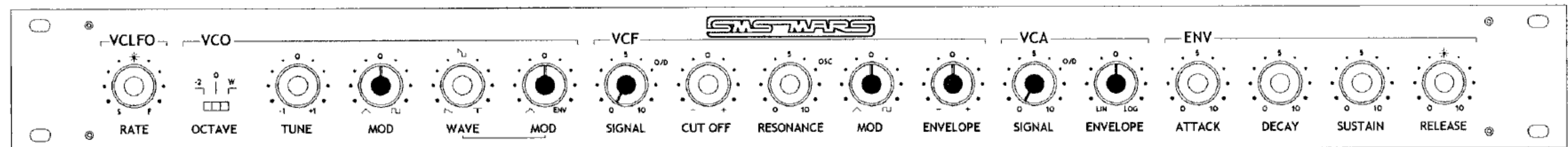

WITH THE HIGHLIGHTED CONTROLS IN THE POSITIONS SHOWN, THERE ARE NO INTERNAL SIGNAL OR MODULATION ROUTES.

VCLFO VOLTAGE CONTROLLED LOW FREQUENCY OSCILLATOR

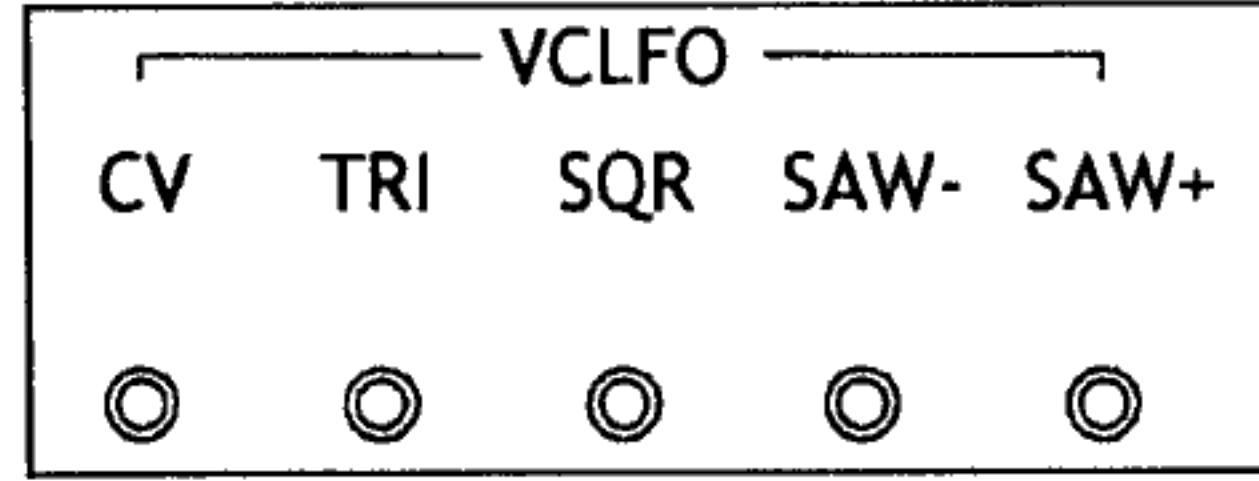
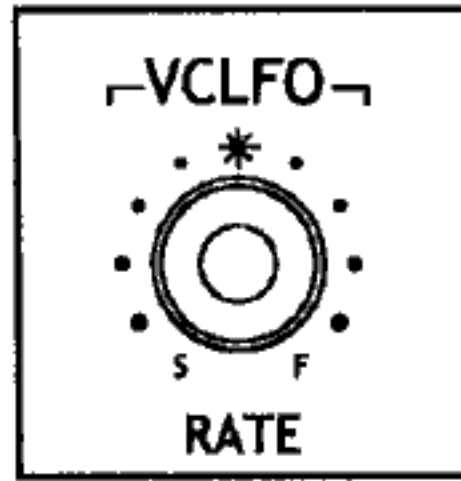

The VCLFO is a wide range oscillator used to modulate control inputs, eg: used for vibrato, tremolo and trill. It is internally routed to the VCO and VCF (see INTERNAL SIGNAL ROUTE page 3).

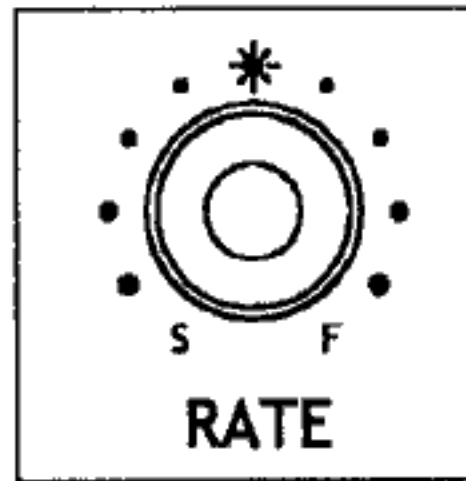

LFO CONTROL

The rate knob controls the speed of the modulation wave form. The LED gives a visual indication of the speed of the VCLFO.

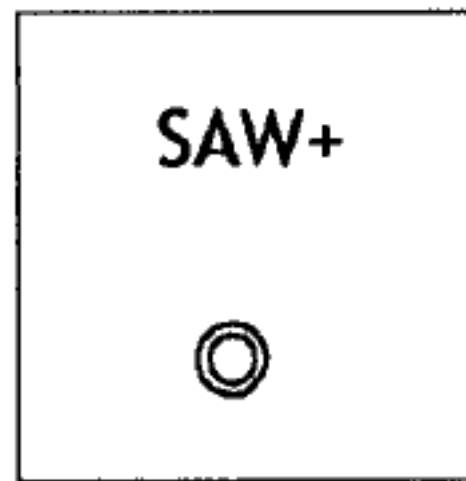

This output gives a positive sawtooth with an output voltage of +/-5 volts.

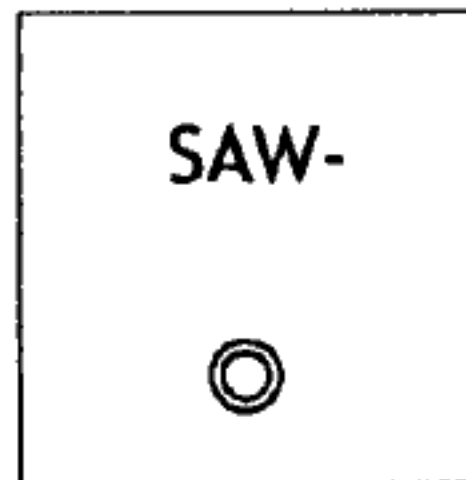

This output gives a negative sawtooth with an output voltage of +/-5 volts.

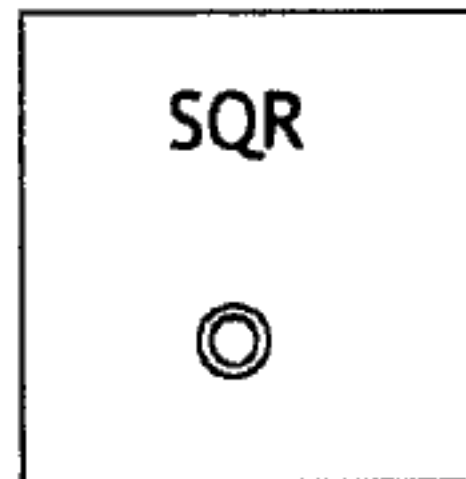

This output gives a square wave output of +/-5 volts

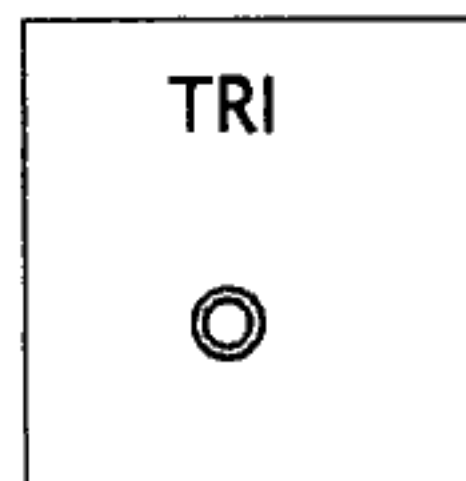

This output gives a triangle wave output of +/-5 volts

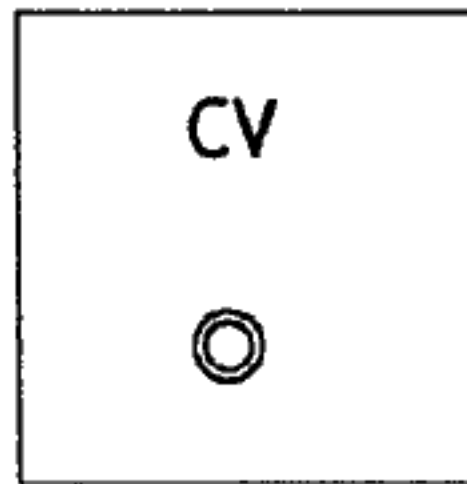

This gives linear control of the VCLFO rate, eg: from keyboard or envelope.

VCO VOLTAGE CONTROLLED OSCILLATOR

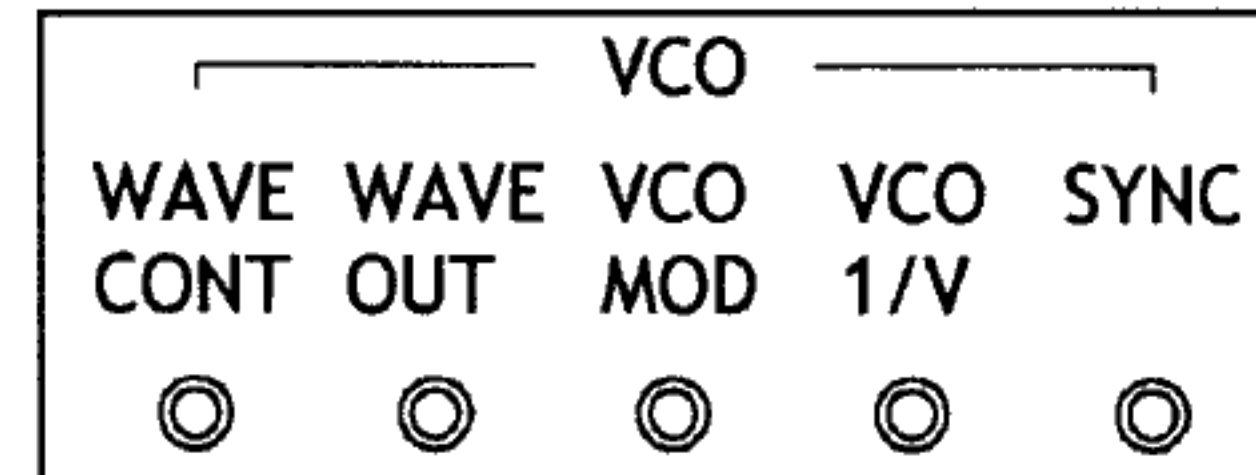
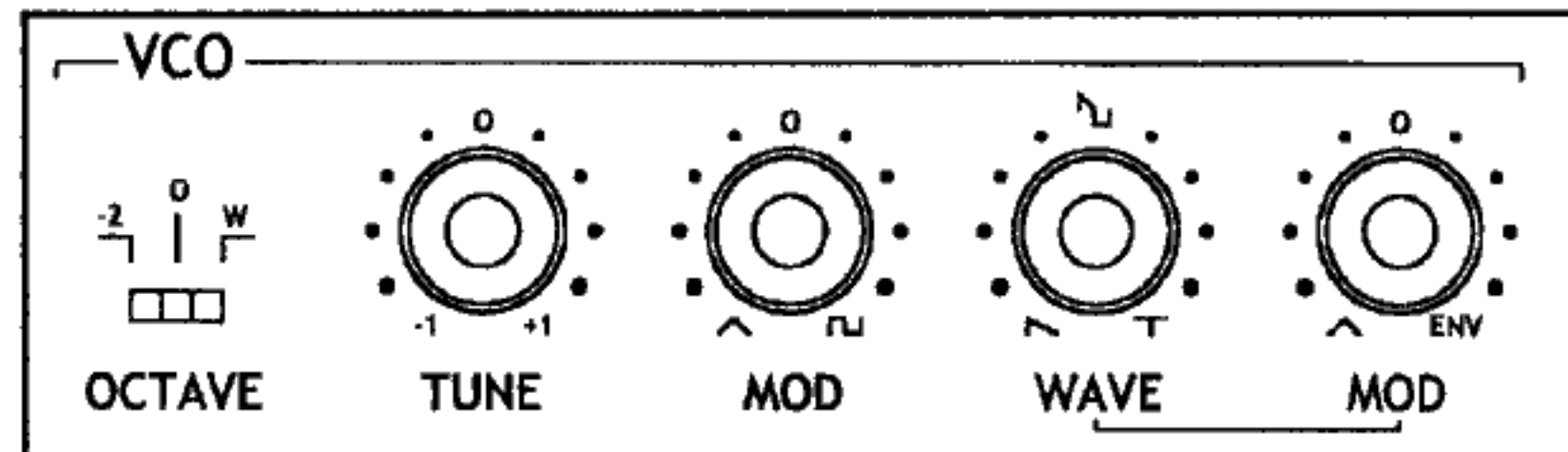

The VCO is the primary sound source within the MARS. It creates the raw waveform which is then processed and modified by the other synthesizer circuits.

FREQUENCY CONTROL

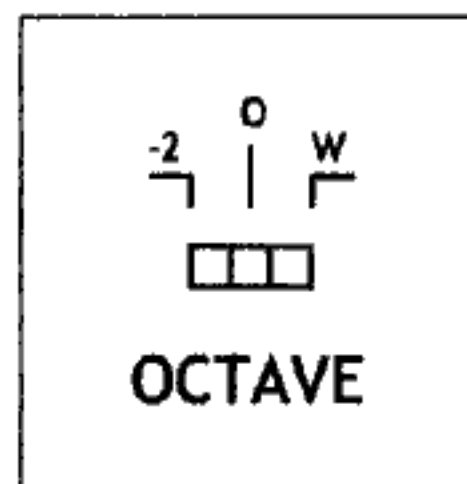

1. In the '-2' position the tune knob controls the initial frequency of 32Hz by +/- one octave.
2. In the '0' position the tune knob controls the initial frequency of 128Hz by +/- one octave.

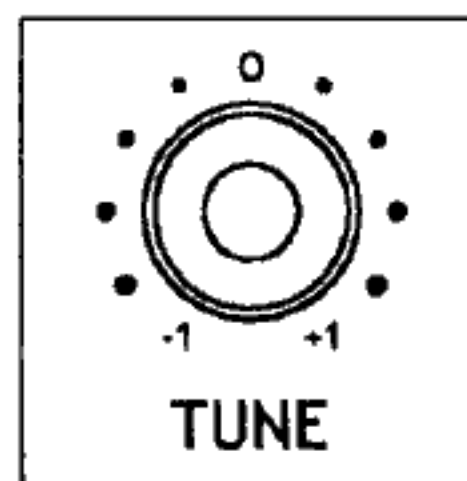

3. In the 'W' position (WIDE) the tune knob has a range of approximately 12 octaves.

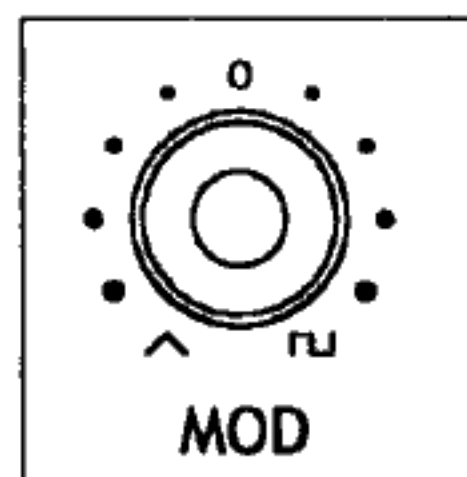

The Modulation knob introduces either triangle, square or no modulation to the oscillators frequency (a maximum of two octaves, from the VCLFO).

WAVE SHAPING

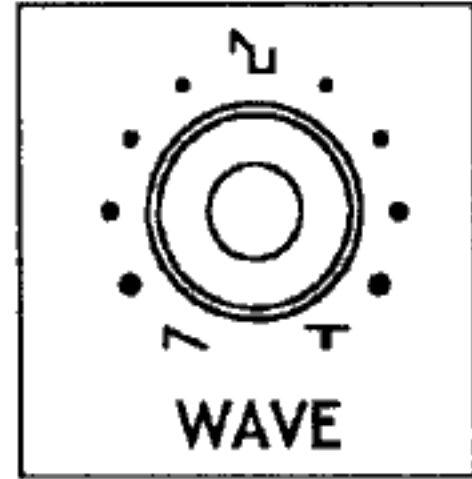

The wave knob controls the initial wave shape from the VCO. In the anti-clockwise position a saw tooth is generated, in the clockwise position a pulse is generated, between the two positions the wave shape alters from sawtooth through various sawtooth/squarewaves to a 2% pulse. The waveform is fully variable with no fixed point.

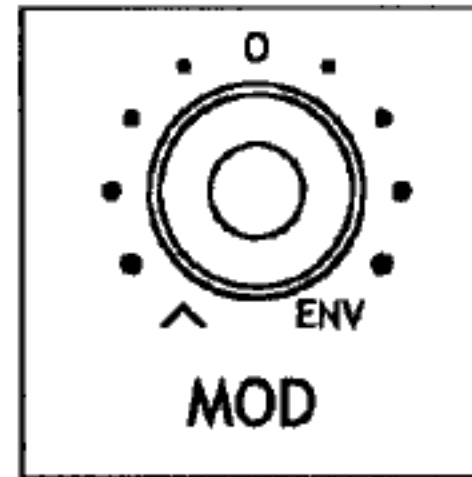

The mod knob controls the amount of triangle modulation (from the VCLFO) or envelope modulation routed to the wave shape. Pulse width modulation can be created using this method.

VCO PATCH POINTS

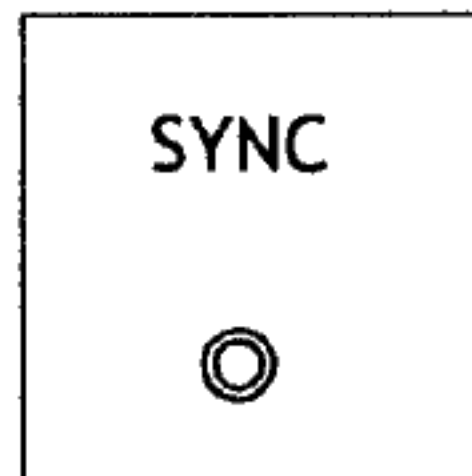

This is a hard sync input used to reset the VCO waveform using a second oscillator. A wide range of frequencies, waveshapes and levels will determine the type of sync generated.

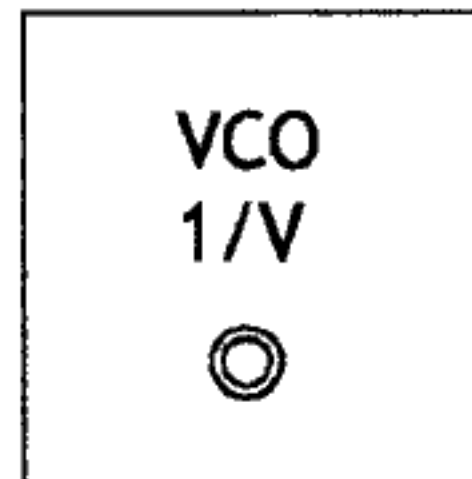

This is the main control voltage input for the VCO frequency and has logarithmic characteristics of one volt per octave, this should be your input from a keyboard/controller.

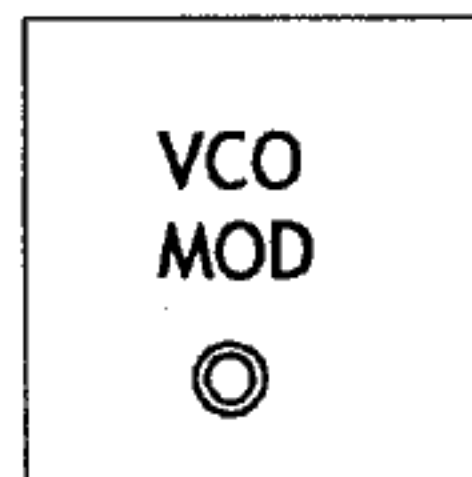

This is similar to the VCO 1/V input but should be used for external modulation, (eg: LFO, sample and hold, ENV).

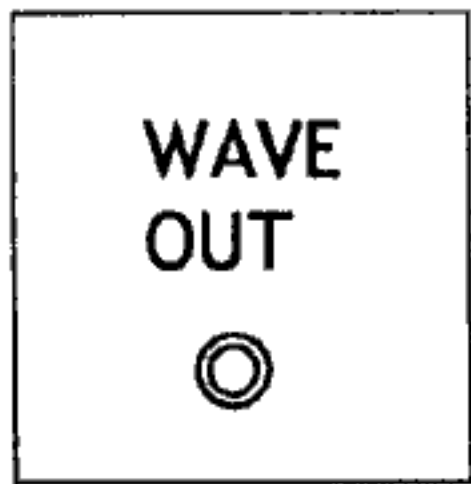

This is the output for the waveshape generated by the VCO.

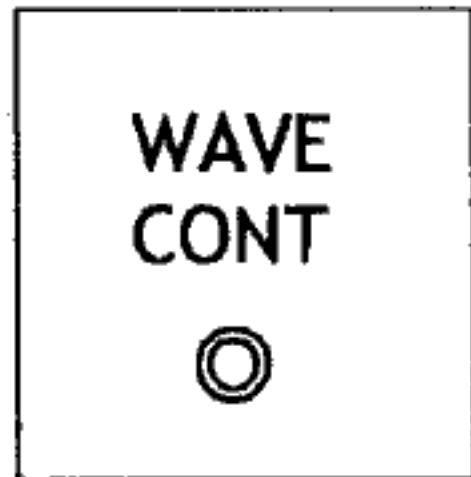

This gives external control of the waveshape generated by the VCO.

VCF VOLTAGE CONTROLLED FILTER

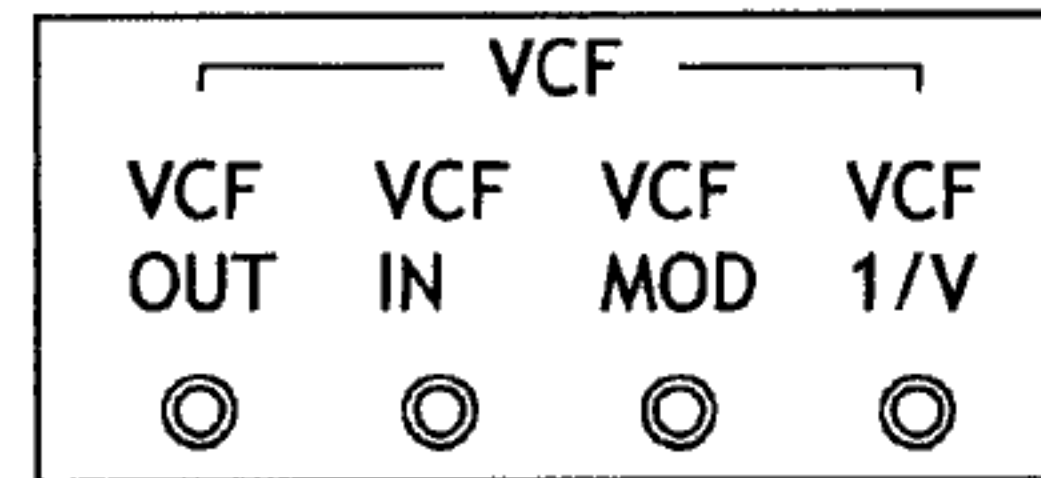
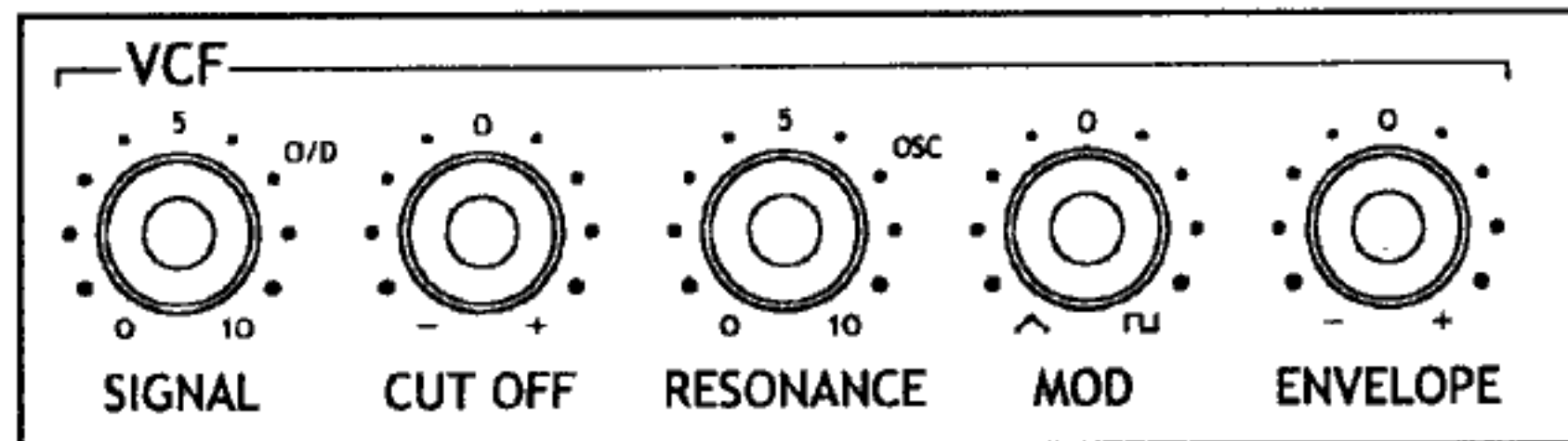

The VCF is a low pass 24dB/oct ladder filter, it has the ability to attenuate/eliminate frequencies above the cut-off point. This type of filter can create sounds associated with classic American analogue synthesizers.

VCF CONTROLS

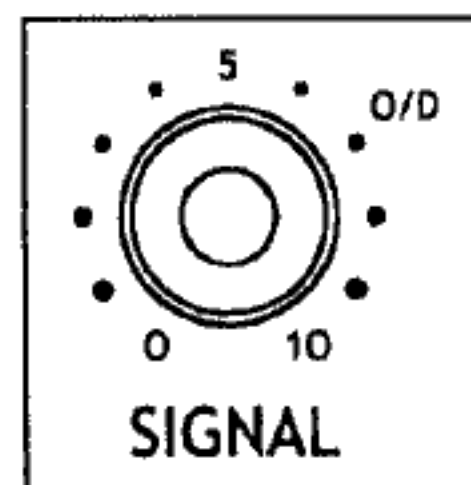

This signal knob controls the audio signal level coming from the VCO into the VCF. The filter may be over-driven in the range of 5 - 10.

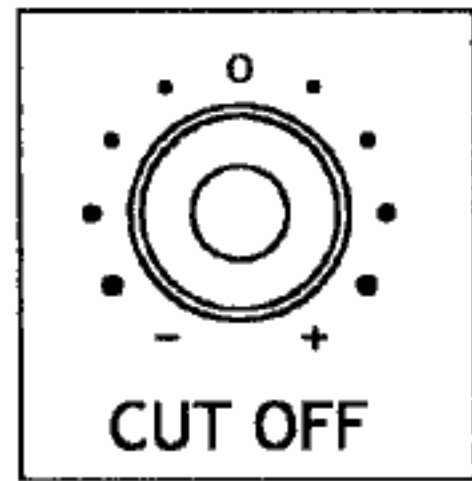

The Cut-off knob controls the point at which attenuation begins. Frequencies above the cut-off point are attenuated at 24dB/oct.

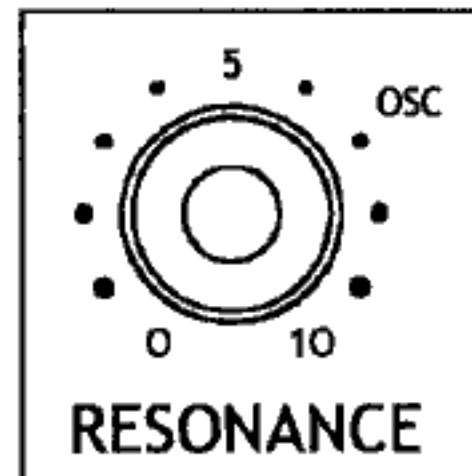

Resonance is used to accentuate frequencies around the cut-off point, as the resonances increase the filter will begin to ring and will self oscillate at high resonate settings producing a sine wave (the frequency of which is controlled by the cut-off knob).

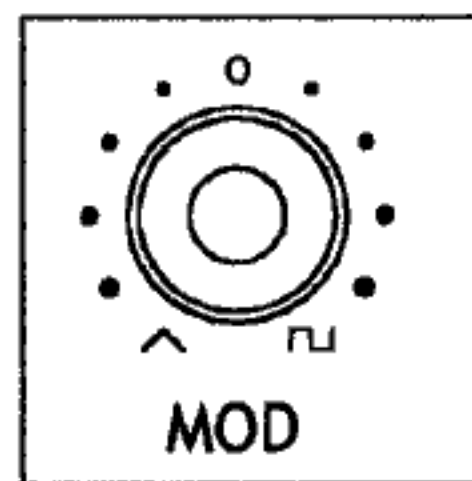

The mod knob introduces either triangle, square (from the VCFLO) or no modulation to the VCF's cut-off point.

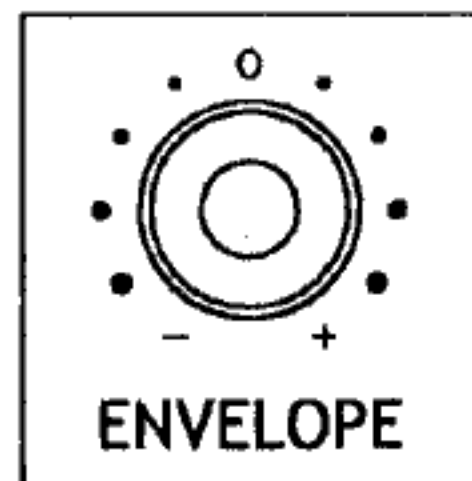

The envelope knob alters the cut-off point according to the set up of the envelope generator allowing automated shaping of the filter negatively and positively.

VCF PATCH POINTS

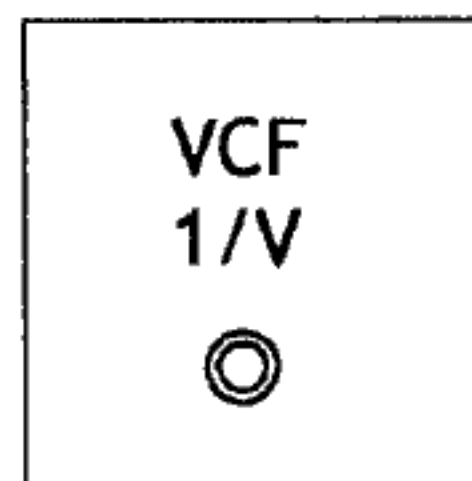

This is the main control voltage input for the VCF and has characteristics of one volt per octave. This should be used as your main control input from a keyboard/ controller.

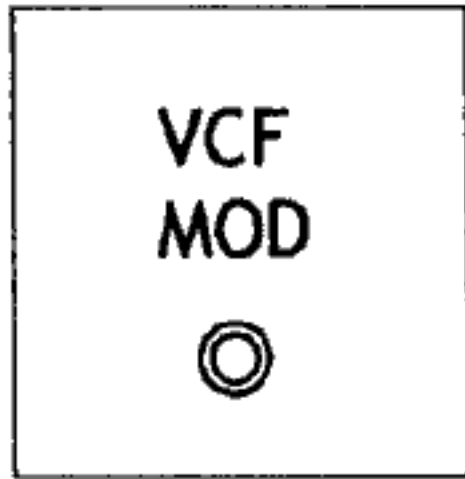

This is similar to the VCF 1/V input but should be used for external modulation.

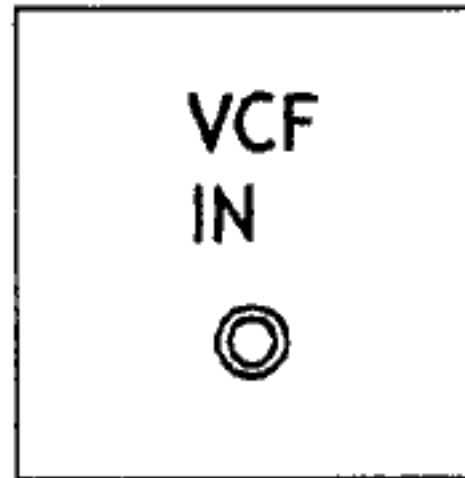

This is an audio input, it allows external signals (audio) to be processed by the VCF. Too much external signal will cause the filter to over-drive or distort.

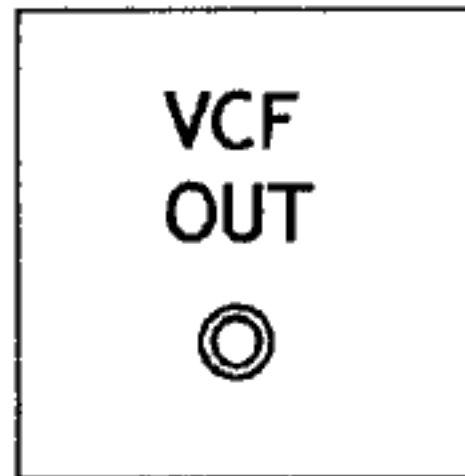

This is the audio output of the filter prior to modification by the VCA.

VCA VOLTAGE CONTROLLED AMPLIFIER

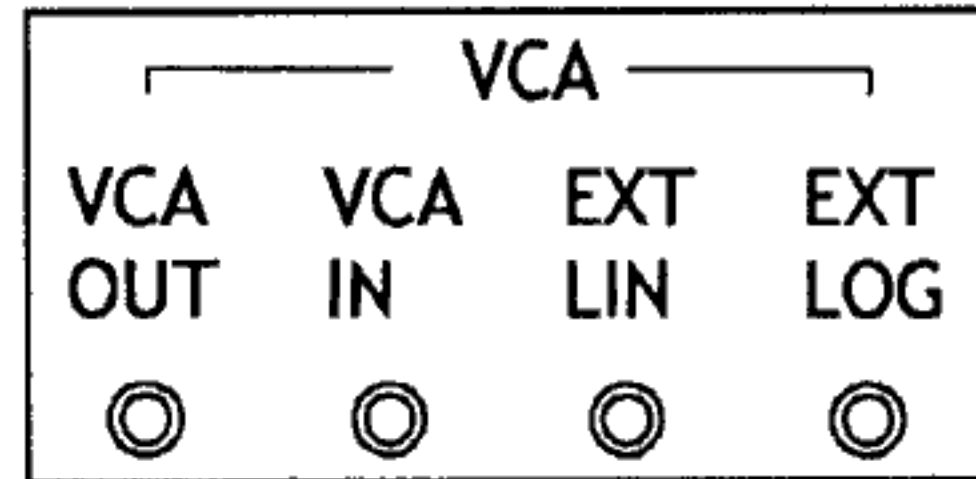
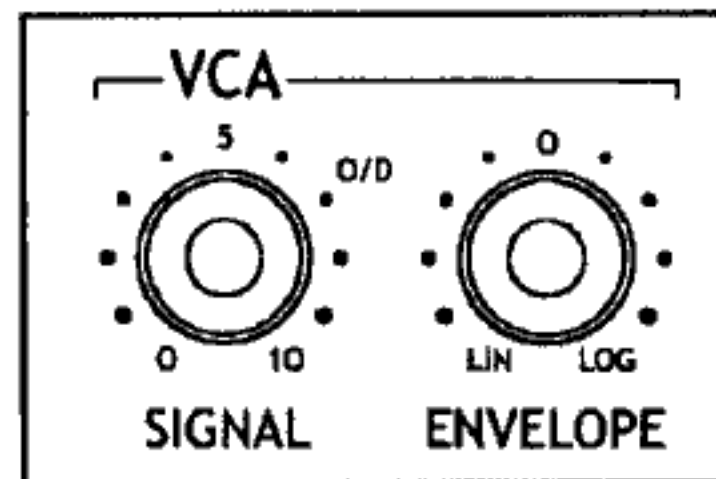

The VCA is an amplifier which allows its gain to be altered by a control voltage. The VCA within the MARS has both logarithmic and linear controls creating unique contours.

VCA CONTROLS

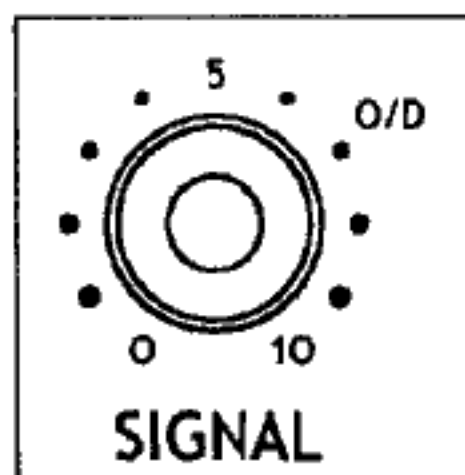

The signal knob controls the audio signal level coming from the VCF into the VCA. The VCA may be over-driven (clipped) in the range of 5 - 10.

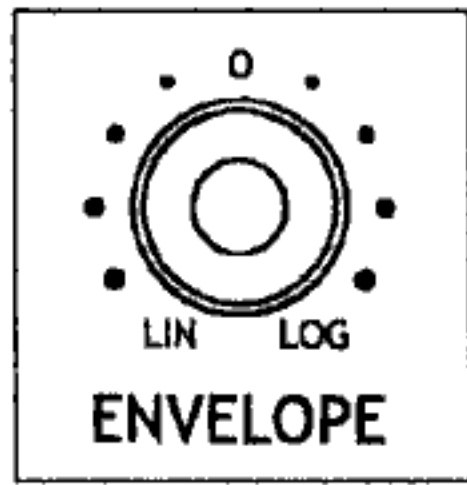

The envelope knob sets the amount of voltage controlled amplification from the envelope generator. Linear and logarithmic control is available giving unique and unusual amplification contours.

VCA PATCH POINTS

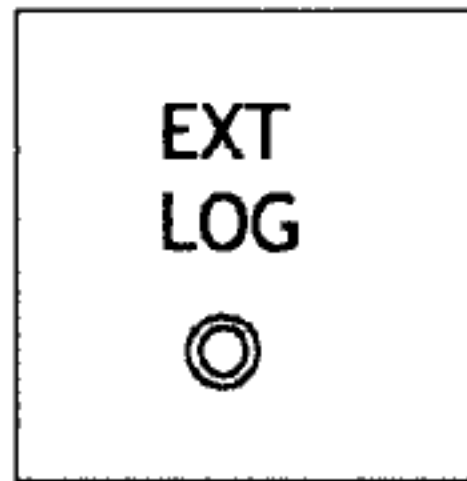

This input allows logarithmic modulation of the VCA by an external source.

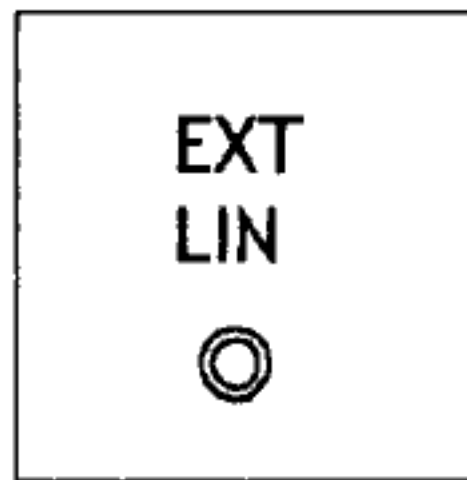

This input allows linear modulation of the VCA by an external source (the usual control input from an envelope generator).

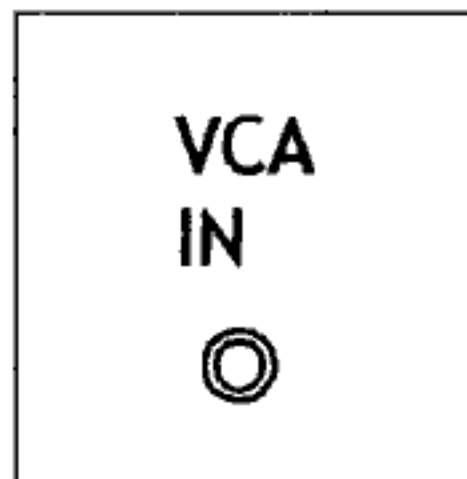

This is an external input that allows audio and control signals to be processed by the VCA.

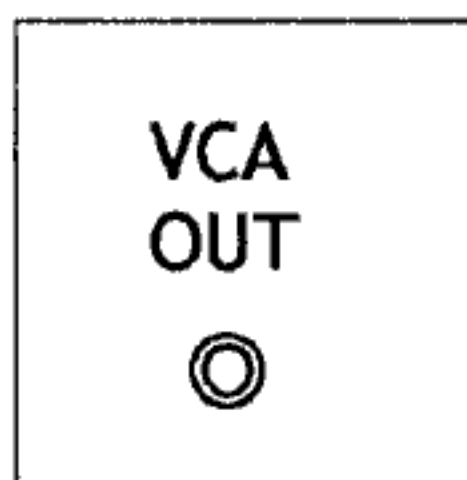

This is the output of the VCA, it is also the final output when used as a complete synthesizer.

ENV ENVELOPE GENERATOR

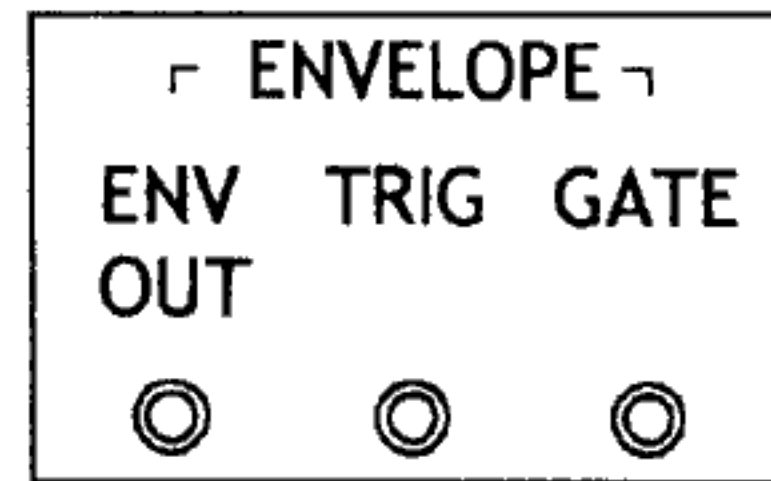
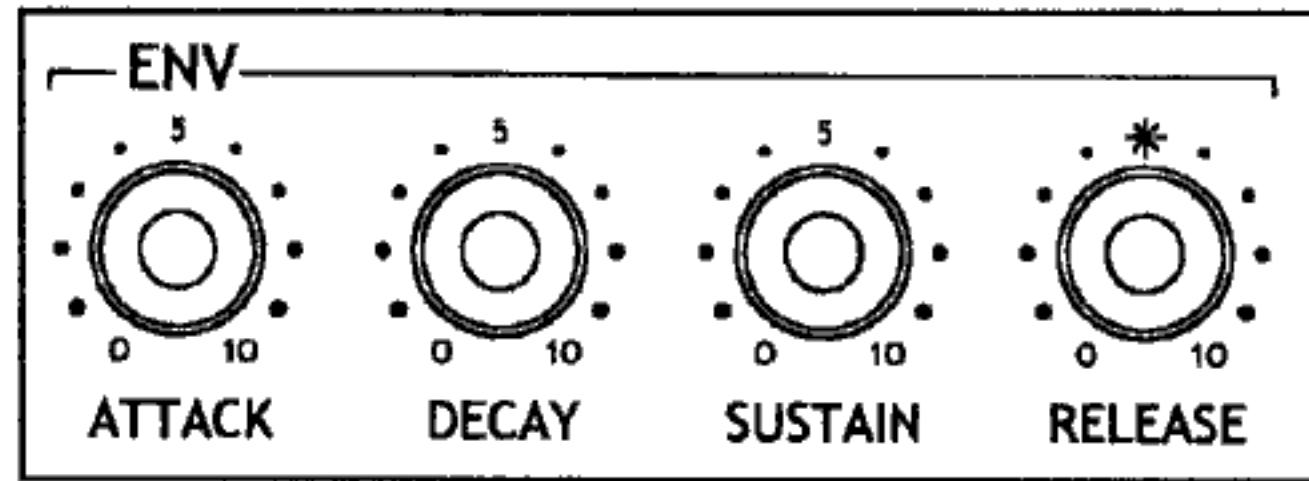

The ENV is a method of generating a control voltage, the waveshape is created in 4 stages: Attack, Decay, Sustain and Release which can be adjusted individually. The output of the ENV can control any voltage controlled input.

ENVELOPE CONTROLS

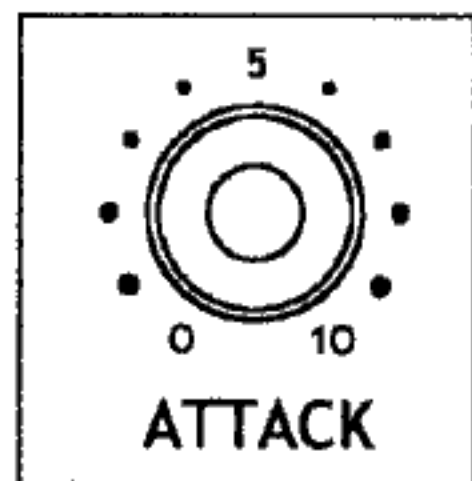

The attack knob controls the amount of time it takes the output voltage to reach the maximum level once the gate is initialised.

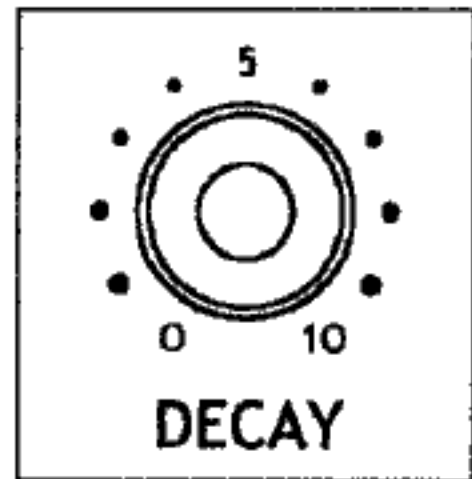

The decay knob controls the amount of time it takes the output voltage to fall to the sustain level once the attack phase is complete, providing the gate has not already ended.

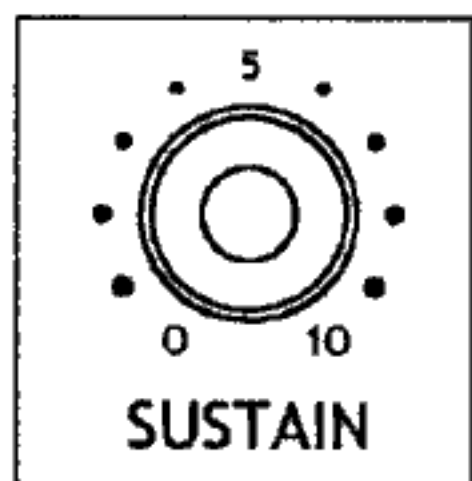

The sustain knob controls the level of the output voltage until the gate ends.



The release knob controls the amount of time it takes the output voltage to fall to '0' once the gate has ended.
The L.E.D. is a visual indication of ENV activity.

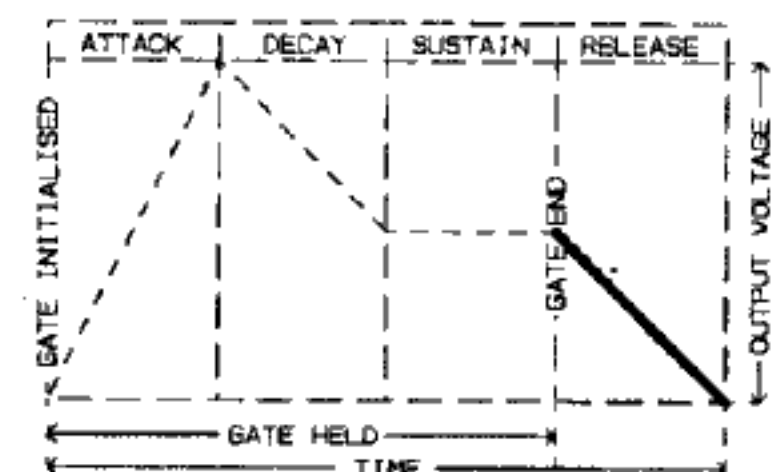
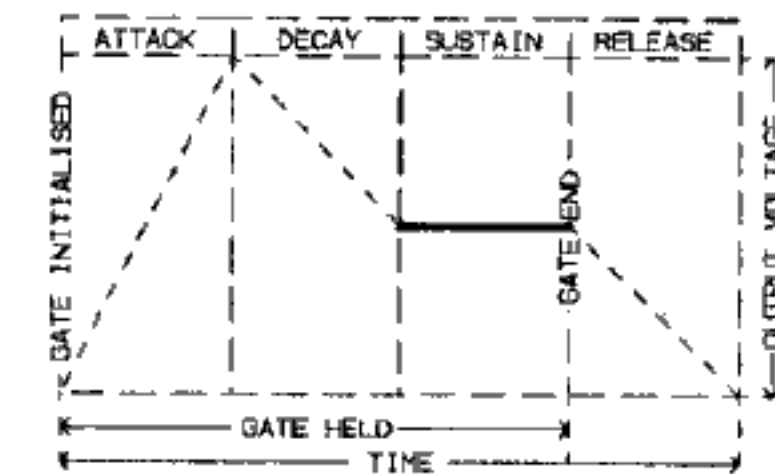
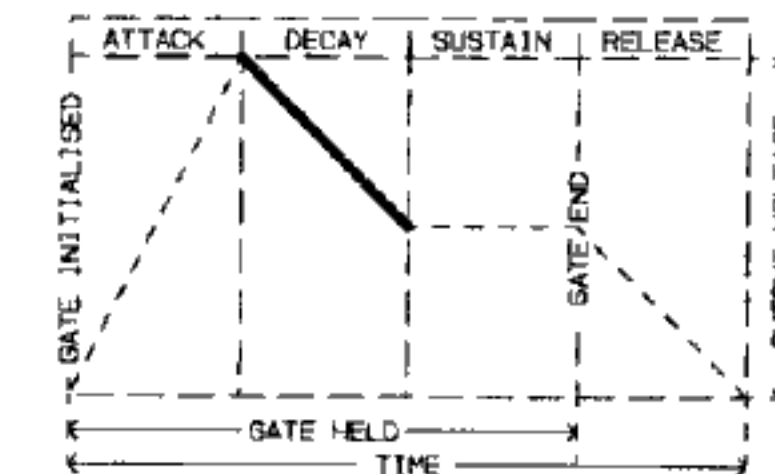
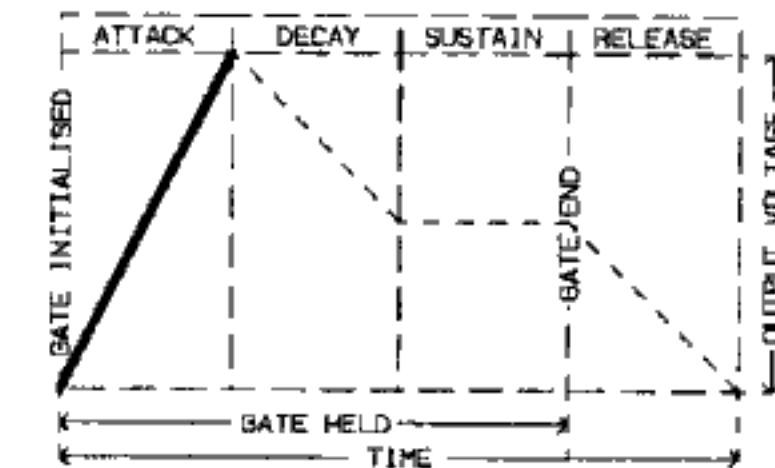

ENV PATCH POINTS

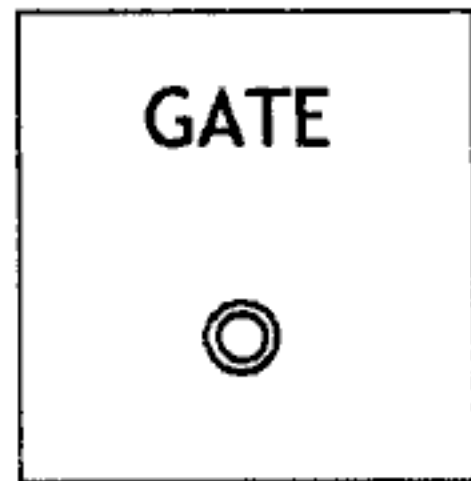

This is an input which initialises the ENV cycle (eg: the gate output from a keyboard/controller with a minimum output of 1 volt).

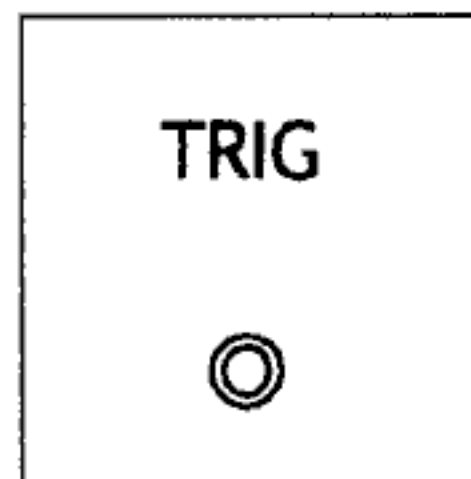

This is the trig/retrig input. A short positive pulse will re-initialise the already gated ENV.

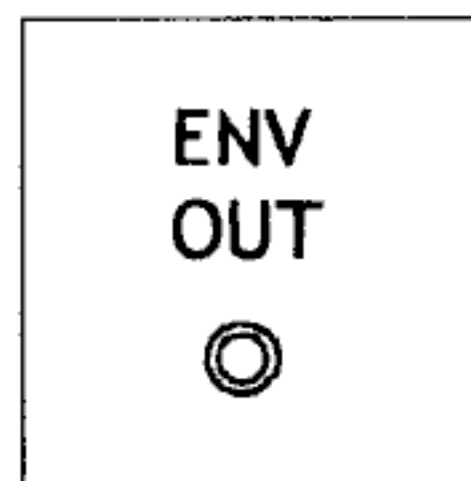

This is the output voltage of the ENV which can be used to control any voltage controlled input.

SPECIFICATION

VCLFO	
Fc Range	0.055 Hz (one cycle per 18 seconds) 33 Hz (33 cycles per second)
Waveforms	Positive and negative sawtooth, square and triangle waveforms available simultaneously 10v peak to peak +/- 5v
VCO	
Fc Range	1.5Hz to 16.5KHz Exponential response 1 volt per octave.
Internal Fc Mod	Square or triangle +/- 1 octave
Waveform	Sawtooth waveform that transfers through square to 2% negative pulse (no fixed point)
Internal Wave Mod	Triangle (VCLFO) envelope. Full positive wave control
Temp Compensation	Factory set at 80 degrees for minimal drift.
VCF	
Type	24dB per octave low pass ladder filter. Transistors and capacitors matched at specific temperature with 0% tolerance.
Fc Range	20 Hz to 20 KHz.
Internal mod	Square or triangle +/- 4 octaves (from VCLFO).
Resonance	Zero to self oscillation.
Envelope Mod	+/- 10 octaves.
VCA	
Gain Control	Internally routed linear or logarythmic control by envelope generator.
ENV	
Gate	1v to 12v positive gate.
Trig/Retrig	1v to 12v positive pulse.
Output Voltage	Zero to 10v (approx).
Attack Time	5ms to 7.5 seconds.
Decay Time	5ms to 15 seconds.
Sustain Level	Zero to 100%.
Release Time	5ms to 15 seconds.

Burn-In	Before final calibration units are burnt-in for a minimum of 96 hours.
Power Requirements	UK: 230v AC 50 Hz (220v - 240v). Export: 115v AC 60Hz (100v - 120v).
Internal Supply	+/- 12v DC 90 mA.
AC Voltage Select	The MARS has an 'AC V. SELECT' switch. It is imperative that this is set correctly. Failure to do so will void warranty and damage the unit beyond repair.
Warranty	The SMS MARS comes with a 12 month (from purchase date) back-to-base warranty, (i.e. customer must arrange and pay for carriage to and from SMS).
Contact Us	Please don't hesitate to get in touch with us for any enquiry: Design/Product Engineer: andy@smssynthesizers.freehosting.net Production Engineer: simon@smssynthesizers.freehosting.net Tel. (44) 01923 661839 www.smssynthesizers.freehosting.net
Thanks To	Paula Allen (Web and Manual Design) graphixdesign.freeservers.com Ian at Action Hardware Bill 'n' Tim at JW Tooling Bob at Analogue Systems Steve "synth-genius" and Gran for making the tea.

Break Out Box

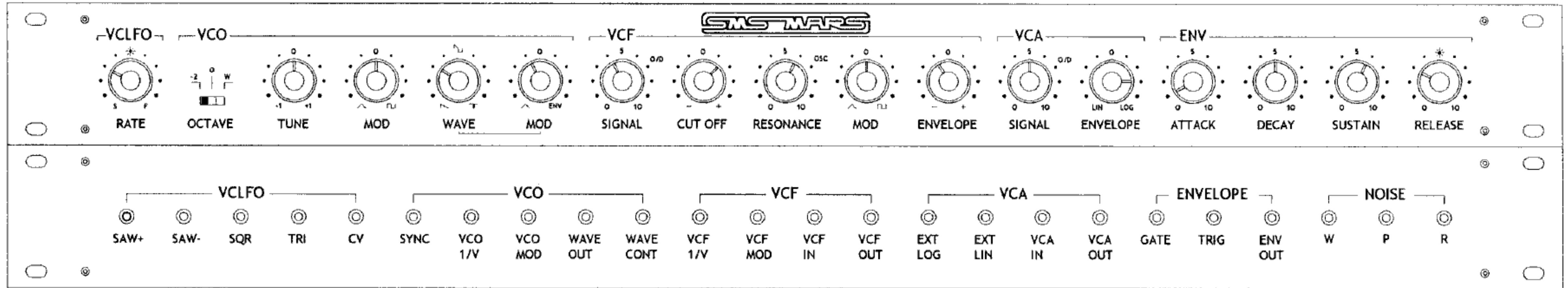

Planet 7

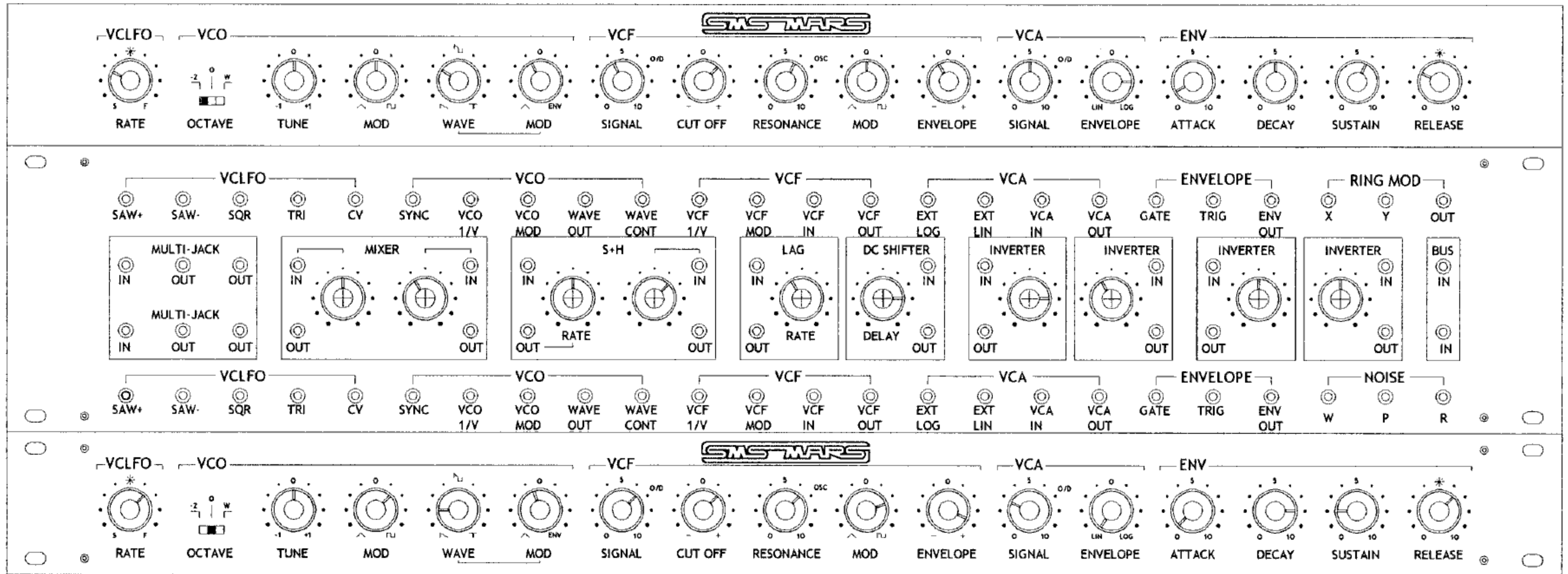

SMS MARS BLANK PATCH SHEETS

© **SMS MARS** ©

VCLFO VCO VCF VCA ENV

RATE OCTAVE TUNE MOD WAVE MOD SIGNAL CUT OFF RESONANCE MOD ENVELOPE SIGNAL ENVELOPE ATTACK DECAY SUSTAIN RELEASE

© **SMS MARS** ©

VCLFO VCO VCF VCA ENV

RATE OCTAVE TUNE MOD WAVE MOD SIGNAL CUT OFF RESONANCE MOD ENVELOPE SIGNAL ENVELOPE ATTACK DECAY SUSTAIN RELEASE

© **SMS MARS** ©

VCLFO VCO VCF VCA ENV

RATE OCTAVE TUNE MOD WAVE MOD SIGNAL CUT OFF RESONANCE MOD ENVELOPE SIGNAL ENVELOPE ATTACK DECAY SUSTAIN RELEASE

© **SMS MARS** ©

VCLFO VCO VCF VCA ENV

RATE OCTAVE TUNE MOD WAVE MOD SIGNAL CUT OFF RESONANCE MOD ENVELOPE SIGNAL ENVELOPE ATTACK DECAY SUSTAIN RELEASE

© **SMS MARS** ©

VCLFO VCO VCF VCA ENV

RATE OCTAVE TUNE MOD WAVE MOD SIGNAL CUT OFF RESONANCE MOD ENVELOPE SIGNAL ENVELOPE ATTACK DECAY SUSTAIN RELEASE